



OIL SKIMMERS - ROS SERIES



Single Phase Belt Skimmer



3 Phase Disk Skimmer



3 Phase Belt Skimmer



Oil Coolant Separator Bin
(Suitable for all models)

CONSTRUCTION

Support Assembly	Powder Coated
Belt	PU
Wiper	Teflon
Driver Pulley	SS410
Driven Pulley	Nylon

OPTIONS

Support Assembly	SS316/304
Belt	SS316
Driven Pulley	SS316/304
Oil Collection Separation Tray	SS316/304

APPLICATION

Types of Fluids	- Oil
	- Coolant Emulsion
	- Mild Chemicals
Liquid Temperature	- 0-50°C for PU Belt
	- 100°C for SS Belt

STANDARD ACCESSORIES

Timer - For ROS1 & ROS2

OPTIONAL

VFD for 3Phase Skimmers
(1Ph input / 3Ph output) for speed control

USED ON

All CNC machines, conventional machines, washing machines, electro plating, grinding machines etc. where floating oil is to be extracted for better life of coolant and finish of components.

Separator bin available for all models in MS Powder coated or SS316, Size: 250 x 150 x 125 ht

DIMENSIONAL DETAILS

Model 1 Phase	Model 3 Phase	Belt width (MM)	Immersion Depth (MM)	Oil Removal Rate (LPH)*	Power in kW	Weight in Kg	
						ROS1	ROS3
ROS1-40-225	ROS3-40-225	40	225	3	0.04	3.7	5.7
ROS1-40-300	ROS3-40-300	40	300	3	0.04	4.0	6.0
ROS1-40-500	ROS3-40-500	40	500	3	0.04	4.2	6.3

* Note : Tested for 32CST oil

* Standard spares : Belt, Driven Pulley, Wiper, Disc

ROS1 - 40 : 1 Phase, Belt Skimmer

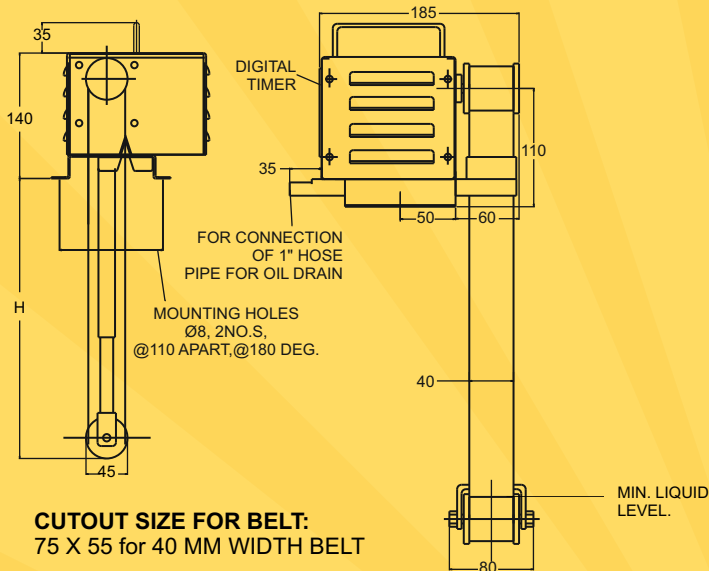

CUTOUT SIZE FOR BELT:
75 X 55 for 40 MM WIDTH BELT

ROS3 - 40 : 3 Phase, Belt Skimmer

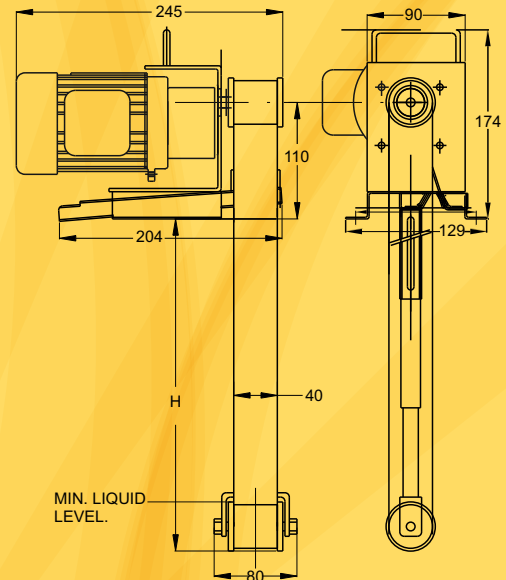

ROS 3 - 80 - 500, 3 Phase, 40w Belt Skimmer

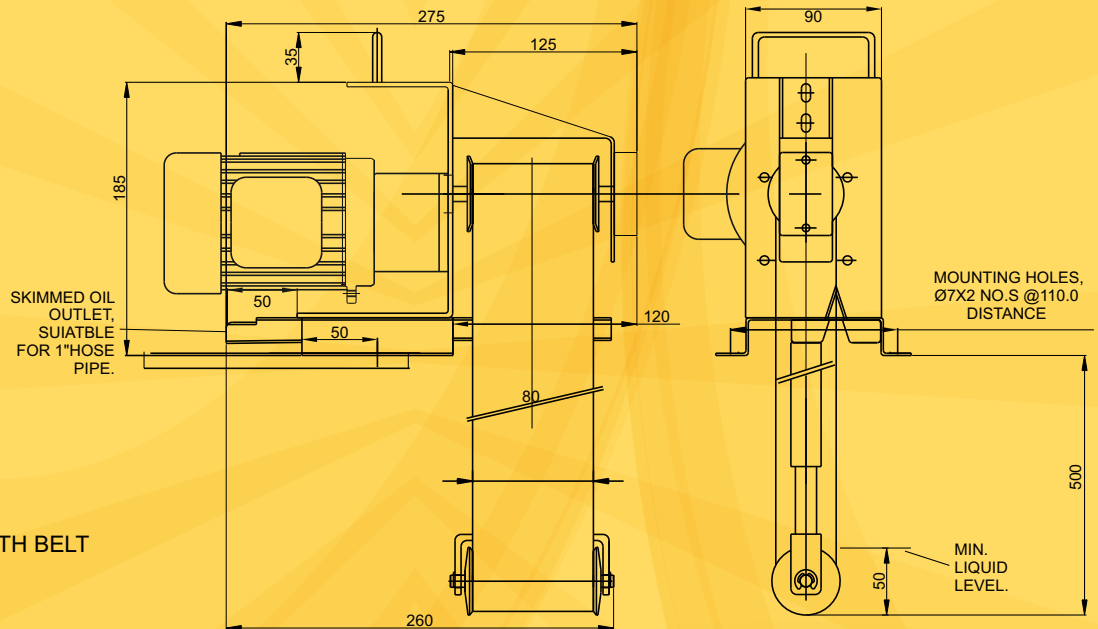

Oil Removal Rate (LPH)*
6

CUTOUT SIZE:
Min. 125 X 60 for 80MM WIDTH BELT
Weight 7.5 kgs

ROS2 Disc Oil Skimmer

Specification :
1 Phase, 230V, 0.04kW
Disc Material: SS316
Weight 3.5 kgs

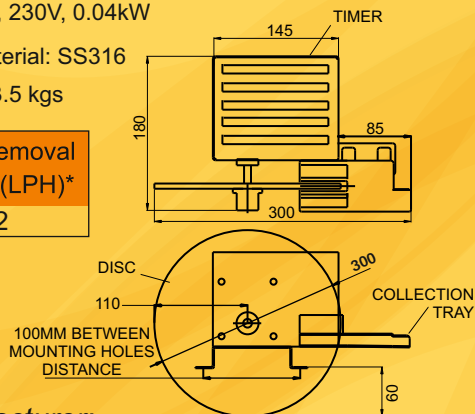

Oil Removal Rate (LPH)*
2

Manufacturer:

Rajamane Industries Pvt Ltd.,
Whitefield Road, Mahadevapura Post,
Bangalore 560 048 India
Ph: +91-80-43659000, Fax: +91-80-28524320
Email : motors@rajamane.com
web: www.rajamane.com

ROS4 Disc Oil Skimmer

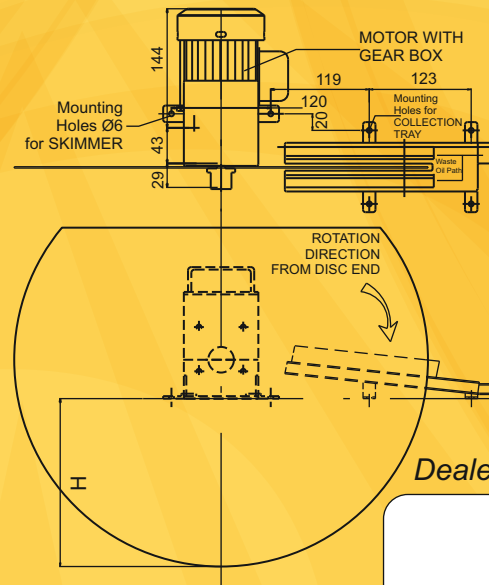

Specification :
3 Phase, 415V, 0.04kW
Disc Material: SS316
Weight 8.5 kgs

DIA	HEIGHT H
Ø400	153
Ø500	203

Oil Removal Rate (LPH)*
5

Dealer: